

## Model

Designation **CU GS21MLX MG\_Z 230/1/50 VAL**



Sales code: 314L7002  
Engineering code: CUGS21MLX00VE

## Application Data

Power supply 220-240V / 50Hz 1~  
Refrigerants R404A-R452A-R449A  
Refr. charge - tech. limit 2000g / 70,5oz  
Starter HST / capillary tube or expansion valve  
Sound pressure (10m) 45,8dB(A)

## Configuration data

	Conf. 1	Conf. 2	Conf. 3
Voltage range	198 - 254V / 50Hz	198 - 254V / 50Hz	198 - 254V / 50Hz
Refrigerant	R404A	R452A	R449A
Application	MBP	MBP	MBP
Rated performance	<u>pe=-10°C, Tsuc=20°C, Tamb=25°C, subcooling: 2K</u>		
Cooling capacity	1917W / 6547Btu/h	1915W / 6541Btu/h	1831W / 6254Btu/h
Power consumption	977,6W	925,9W	871,3W
Current consumption	4,6A	5,4A	4,2A
COP/EER	1,96 / 6,7Btu/Wh	2,07 / 7,06Btu/Wh	2,1 / 7,18Btu/Wh
Approvals	Eco design (EU) 2015/1095, CE, UK CA, VDE	Eco design (EU) 2015/1095, CE, UK CA, VDE	Eco design (EU) 2015/1095, CE

## Compressor

Designation **GS21MLX**  
Motor configuration CSCR  
Locked rotor amperage 24A  
Rated load amperage 4,7A  
Winding resistance main 2,5Ω  
Winding resistance aux 6,7Ω  
Oil quantity 900cm<sup>3</sup> / 30,4fl.oz  
Oil type POE  
Horsepower rating 1 HP

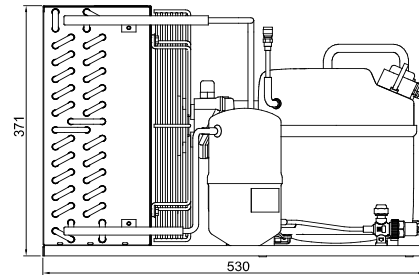

## Dimensions

### Condensing unit

Height x Width x Depth 371 x 430 x 530 [mm] / 14,6 x 16,9 x 20,9 [in]  
Weight 33,9kg / 74,7lbs  
Suction adapter FLARE 1/2"  
Discharge adapter FLARE 1/4"  
Process connector ø6,5mm / 0,26in

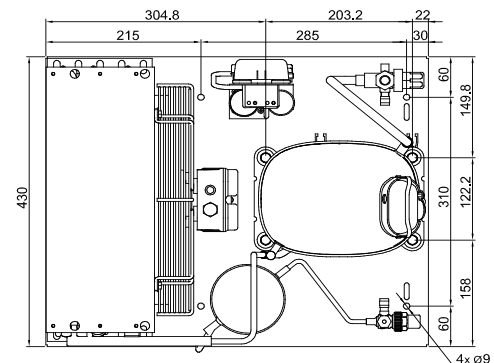

### Package data

Height x Width x Depth 450 x 600 x 700 [mm] / 17,7 x 23,6 x 27,6 [in]  
Weight 37,9kg / 83,6lbs

## Model

Designation **CU GS21MLX MG\_Z 230/1/50 VAL**

Sales code: 314L7002

Engineering code: CUGS21MLX00VE

## Components Condensing-Unit / Spare Parts

Component	Type	Spare part code number
Compressor code	GS21MLX	107B0523
Condenser	Condenser (4 rows x 14 tubes)	SP 314S0006
Fan motor	35W	MP 314S0020
Blade code	ø300mm 28°	SP 314S0030
Air flow	1034,4m³/h	
Receiver code	Receiver 1,3 liter	MP 314S0036
Suction valve code	FLARE 1/2"	FLARE 1/2"
Liquid valve code	FLARE 1/4"	FLARE 1/4"

Compressor starting equipment	Spare part code number
pos. a3 - GS starter kit (600mm)	117-7070
pos. b - cover	107B9101
pos. b2 - gasket	107B9100
pos. b1 - clamp	107B9104

## Wiring Sketch Compressor

## Wiring Sketch Condensing Unit

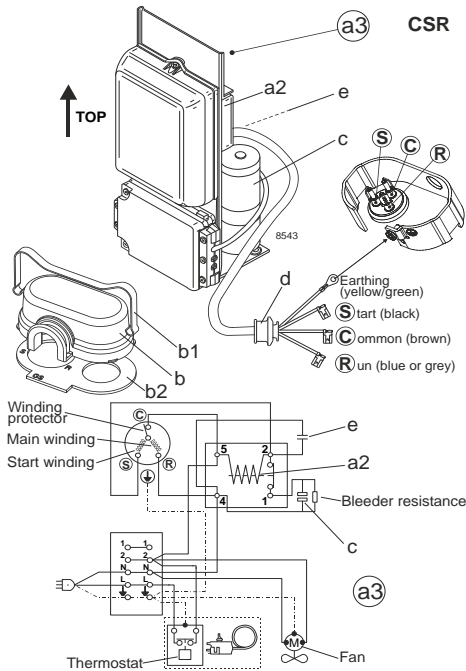

## Model

Designation **CU GS21MLX MG\_Z 230/1/50 VAL**

Sales code: 314L7002

Engineering code: CUGS21MLX00VE

## Cooling performance - Conf. 1

Power supply	220-240V / 50Hz 1~	Voltage range	198 - 254V / 50Hz
Refr. charge - tech. limit	2000g / 70,5oz		
Starter	HST / capillary tube or expansion valve		
Motor configuration	CSCR		
Refrigerant	R404A		
Application	MBP		
Approvals	Eco design (EU) 2015/1095, CE, UK CA, VDE		

ambient temperature	[°C / °F]	25 / 77 (suction gas temperature [°C / °F]: 20 / 68, subcooling: 2K)						
evaporating temperature	[°C / °F]	-20 / -4	-15 / 5	-10 / 14	-5 / 23	0 / 32	5 / 41	10 / 50
cooling capacity	[W]	1322	1605	1917	2252	2604	2965	3329
COP	[W/W]	1,64	1,81	1,96	2,09	2,19	2,26	2,29
cooling capacity	[Btu/h]	4515	5481	6547	7690	8893	10127	11370
power consumption	[W]	806	889	978	1076	1187	1312	1456
current consumption	[A]	3,8	4,2	4,6	5,1	5,6	6,2	6,8

ambient temperature	[°C / °F]	32 / 90 (suction gas temperature [°C / °F]: 20 / 68, subcooling: 2K)				
evaporating temperature	[°C / °F]	-20 / -4	-15 / 5	-10 / 14	-5 / 23	0 / 32
cooling capacity	[W]	1155	1406	1680	1975	2280
COP	[W/W]	1,39	1,52	1,64	1,74	1,82
cooling capacity	[Btu/h]	3946	4801	5739	6743	7788
power consumption	[W]	828	923	1023	1133	1255
current consumption	[A]	3,9	4,4	4,8	5,4	5,9

ambient temperature	[°C / °F]	38 / 100 (suction gas temperature [°C / °F]: 20 / 68, subcooling: 2K)		
evaporating temperature	[°C / °F]	-20 / -4	-15 / 5	-10 / 14
cooling capacity	[W]	1020	1242	1484
COP	[W/W]	1,21	1,3	1,39
cooling capacity	[Btu/h]	3482	4242	5067
power consumption	[W]	845	952	1065
current consumption	[A]	4	4,5	5

ambient temperature	[°C / °F]	43 / 109 (suction gas temperature [°C / °F]: 20 / 68, subcooling: 2K)
evaporating temperature	[°C / °F]	-20 / -4
cooling capacity	[W]	910
COP	[W/W]	1,06
cooling capacity	[Btu/h]	3108
power consumption	[W]	858
current consumption	[A]	4,1

## Model

Designation **CU GS21MLX MG\_Z 230/1/50 VAL**

Sales code: 314L7002

Engineering code: CUGS21MLX00VE

## Cooling performance - Conf. 2

Power supply	220-240V / 50Hz 1~	Voltage range	198 - 254V / 50Hz
Refr. charge - tech. limit	2000g / 70,5oz		
Starter	HST / capillary tube or expansion valve		
Motor configuration	CSCR		
Refrigerant	R452A		
Application	MBP		
Approvals	Eco design (EU) 2015/1095, CE, UK CA, VDE		

ambient temperature	[°C / °F]	25 / 77 (suction gas temperature [°C / °F]: 20 / 68, subcooling: 2K)						
evaporating temperature	[°C / °F]	-20 / -4	-15 / 5	-10 / 14	-5 / 23	0 / 32	5 / 41	10 / 50
cooling capacity	[W]	1297	1589	1915	2272	2653	3054	3464
COP	[W/W]	1,72	1,9	2,07	2,22	2,33	2,41	2,44
cooling capacity	[Btu/h]	4429	5425	6541	7759	9060	10429	11830
power consumption	[W]	756	837	926	1025	1138	1268	1420
current consumption	[A]	4,6	5	5,4	5,8	6,3	6,8	7,5

ambient temperature	[°C / °F]	32 / 90 (suction gas temperature [°C / °F]: 20 / 68, subcooling: 2K)				
evaporating temperature	[°C / °F]	-20 / -4	-15 / 5	-10 / 14	-5 / 23	0 / 32
cooling capacity	[W]	1141	1403	1694	2011	2350
COP	[W/W]	1,47	1,61	1,75	1,86	1,95
cooling capacity	[Btu/h]	3895	4792	5786	6869	8025
power consumption	[W]	776	869	969	1079	1204
current consumption	[A]	4,7	5,1	5,6	6	6,6

ambient temperature	[°C / °F]	38 / 100 (suction gas temperature [°C / °F]: 20 / 68, subcooling: 2K)		
evaporating temperature	[°C / °F]	-20 / -4	-15 / 5	-10 / 14
cooling capacity	[W]	1014	1249	1510
COP	[W/W]	1,28	1,39	1,5
cooling capacity	[Btu/h]	3463	4267	5155
power consumption	[W]	791	896	1007
current consumption	[A]	4,8	5,2	5,7

ambient temperature	[°C / °F]	43 / 109 (suction gas temperature [°C / °F]: 20 / 68, subcooling: 2K)	
evaporating temperature	[°C / °F]	-20 / -4	
cooling capacity	[W]	912	
COP	[W/W]	1,14	
cooling capacity	[Btu/h]	3115	
power consumption	[W]	803	
current consumption	[A]	4,8	

## Model

Designation **CU GS21MLX MG\_Z 230/1/50 VAL**

Sales code: 314L7002

Engineering code: CUGS21MLX00VE

## Cooling performance - Conf. 3

Power supply	220-240V / 50Hz 1~	Voltage range	198 - 254V / 50Hz
Refr. charge - tech. limit	2000g / 70,5oz		
Starter	HST / capillary tube or expansion valve		
Motor configuration	CSCR		
Refrigerant	R449A		
Application	MBP		
Approvals	Eco design (EU) 2015/1095, CE		

ambient temperature	[°C / °F]	25 / 77 (suction gas temperature [°C / °F]: 20 / 68, subcooling: 2K)						
evaporating temperature	[°C / °F]	-15 / 5	-10 / 14	-6,7 / 20	-5 / 23	0 / 32	5 / 41	10 / 50
cooling capacity	[W]	1502	1831	2068	2197	2595	3020	3467
COP	[W/W]	1,91	2,1	2,22	2,27	2,41	2,51	2,56
cooling capacity	[Btu/h]	5130	6252	7064	7504	8861	10314	11841
power consumption	[W]	786	871	933	967	1076	1204	1354
current consumption	[A]	3,8	4,2	4,5	4,6	5,1	5,6	6,3

ambient temperature	[°C / °F]	32 / 90 (suction gas temperature [°C / °F]: 20 / 68, subcooling: 2K)						
evaporating temperature	[°C / °F]	-15 / 5	-10 / 14	-6,7 / 20	-5 / 23	0 / 32		
cooling capacity	[W]	1337	1635	1849	1965	2325		
COP	[W/W]	1,64	1,79	1,88	1,93	2,04		
cooling capacity	[Btu/h]	4568	5585	6315	6712	7940		
power consumption	[W]	817	912	981	1019	1140		
current consumption	[A]	3,9	4,4	4,7	4,8	5,4		

ambient temperature	[°C / °F]	38 / 100 (suction gas temperature [°C / °F]: 20 / 68, subcooling: 2K)						
evaporating temperature	[°C / °F]	-15 / 5	-10 / 14	-6,7 / 20	-5 / 23			
cooling capacity	[W]	1202	1473	1667	1773			
COP	[W/W]	1,43	1,55	1,62	1,66			
cooling capacity	[Btu/h]	4106	5029	5694	6054			
power consumption	[W]	842	949	1026	1067			
current consumption	[A]	4,1	4,5	4,9	5			

ambient temperature	[°C / °F]	43 / 109 (suction gas temperature [°C / °F]: 20 / 68, subcooling: 2K)						
evaporating temperature	[°C / °F]	-15 / 5						
cooling capacity	[W]	1094						
COP	[W/W]	1,27						
cooling capacity	[Btu/h]	3735						
power consumption	[W]	864						
current consumption	[A]	4,1						