

## Model

Designation **CU GS26MFX MG\_Y 230/1/50 VAL**



Sales code: 314G7005  
Engineering code: CUGS26MFX00VE

## Application Data

Power supply	220-240V / 50Hz 1~
Refrigerants	R134a-R513A
Refr. charge - tech. limit	2000g / 70,5oz
Starter	HST / capillary tube or expansion valve
Sound pressure (10m)	45,2dB(A)

## Configuration data

	Conf. 1	Conf. 2
Voltage range	198 - 254V / 50Hz	198 - 254V / 50Hz
Refrigerant	R134a	R513A
Application	MBP	MBP

Rated performance	<u>pe=-10°C, Tsuc=20°C, Tamb=25°C, subcooling: 2K</u>	
Cooling capacity	1372W / 4687Btu/h	1438W / 4910Btu/h
Power consumption	715,8W	765,3W
Current consumption	3,3A	3,6A
COP/EER	1,92 / 6,55Btu/Wh	1,88 / 6,42Btu/Wh

Approvals	Eco design (EU) 2015/1095, CE, UK CA, VDE	Eco design (EU) 2015/1095, CE, UK CA, VDE
-----------	--	--

## Compressor

Designation	<b>GS26MFX</b>
Motor configuration	CSCR
Locked rotor amperage	20A
Rated load amperage	3,8A
Winding resistance main	3,7Ω
Winding resistance aux	4Ω
Oil quantity	900cm <sup>3</sup> / 30,4fl.oz
Oil type	POE
Horsepower rating	3/5 HP

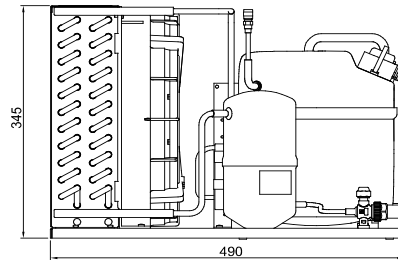

## Dimensions

### Condensing unit

Height x Width x Depth	345 x 390 x 490 [mm] / 13,6 x 15,4 x 19,3 [in]
Weight	33,5kg / 73,9lbs
Suction adapter	FLARE 1/2"
Discharge adapter	FLARE 1/4"
Process connector	ø6,5mm / 0,26in

### Package data

Height x Width x Depth	400 x 500 x 600 [mm] / 15,7 x 19,7 x 23,6 [in]
Weight	37,5kg / 82,7lbs

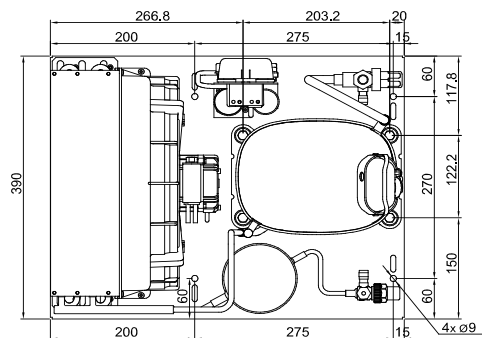

## Model

Designation **CU GS26MFX MG\_Y 230/1/50 VAL**

Sales code: 314G7005  
Engineering code: CUGS26MFX00VE

## Components Condensing-Unit / Spare Parts

Component	Type	Spare part code number
Compressor code	GS26MFX	107B0700
Condenser	Condenser (4 rows x 13 tubes)	SP 314S0005
Fan motor	35W	MP 314S0020
Blade code	ø300mm 28°	SP 314S0030
Air flow	912,8m³/h	
Receiver code	Receiver 1,3 liter	MP 314S0036
Suction valve code	FLARE 1/2"	FLARE 1/2"
Liquid valve code	FLARE 1/4"	FLARE 1/4"

Compressor starting equipment	Spare part code number
pos. a3 - GS starter kit (600mm)	117-7055
pos. b - cover	107B9101
pos. b2 - gasket	107B9100
pos. b1 - clamp	107B9104

## Wiring Sketch Compressor

## Wiring Sketch Condensing Unit

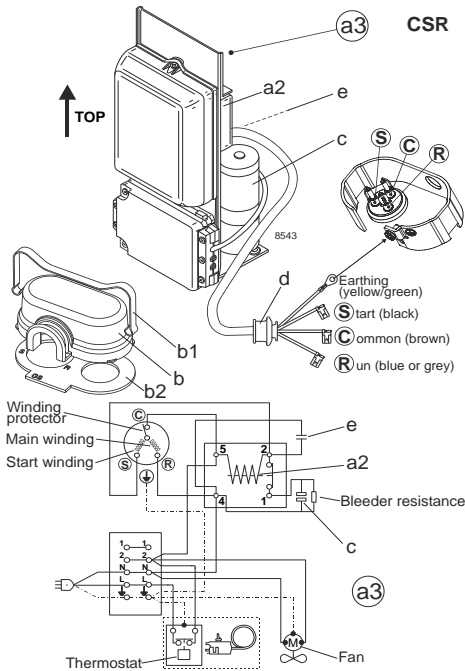

## Model

Designation **CU GS26MFX MG\_Y 230/1/50 VAL**

Sales code: 314G7005

Engineering code: CUGS26MFX00VE

## Cooling performance - Conf. 1

Power supply	220-240V / 50Hz 1~	Voltage range	198 - 254V / 50Hz
Refr. charge - tech. limit	2000g / 70,5oz		
Starter	HST / capillary tube or expansion valve		
Motor configuration	CSCR		
Refrigerant	R134a		
Application	MBP		
Approvals	Eco design (EU) 2015/1095, CE, UK CA, VDE		

ambient temperature	[°C / °F]	25 / 77 (suction gas temperature [°C / °F]: 20 / 68, subcooling: 2K)						
evaporating temperature	[°C / °F]	-20 / -4	-17,8 / 0	-15 / 5	-10 / 14	-5 / 23	0 / 32	5 / 41
cooling capacity	[W]	875	975	1110	1372	1659	1967	2290
COP	[W/W]	1,54	1,63	1,74	1,92	2,07	2,19	2,25
cooling capacity	[Btu/h]	2988	3329	3790	4686	5665	6717	7821
power consumption	[W]	567	598	639	716	802	900	1016
current consumption	[A]	2,7	2,8	3	3,3	3,7	4,2	4,8

ambient temperature	[°C / °F]	32 / 90 (suction gas temperature [°C / °F]: 20 / 68, subcooling: 2K)						
evaporating temperature	[°C / °F]	-20 / -4	-17,8 / 0	-15 / 5	-10 / 14	-5 / 23	0 / 32	5 / 41
cooling capacity	[W]	795	887	1010	1248	1507	1783	2073
COP	[W/W]	1,38	1,45	1,54	1,69	1,81	1,89	1,93
cooling capacity	[Btu/h]	2716	3029	3449	4262	5146	6089	7080
power consumption	[W]	577	610	654	738	834	944	1073
current consumption	[A]	2,7	2,9	3	3,4	3,9	4,4	5,1

ambient temperature	[°C / °F]	38 / 100 (suction gas temperature [°C / °F]: 20 / 68, subcooling: 2K)						
evaporating temperature	[°C / °F]	-20 / -4	-17,8 / 0	-15 / 5	-10 / 14	-5 / 23	0 / 32	
cooling capacity	[W]	728	812	925	1142	1376	1625	
COP	[W/W]	1,24	1,31	1,38	1,5	1,59	1,65	
cooling capacity	[Btu/h]	2485	2773	3159	3900	4700	5551	
power consumption	[W]	586	621	668	760	864	985	
current consumption	[A]	2,8	2,9	3,1	3,5	4	4,6	

ambient temperature	[°C / °F]	43 / 109 (suction gas temperature [°C / °F]: 20 / 68, subcooling: 2K)						
evaporating temperature	[°C / °F]	-20 / -4	-17,8 / 0	-15 / 5	-10 / 14	-5 / 23		
cooling capacity	[W]	669	748	852	1052	1266		
COP	[W/W]	1,13	1,19	1,25	1,35	1,42		
cooling capacity	[Btu/h]	2285	2553	2910	3592	4323		
power consumption	[W]	594	631	681	780	892		
current consumption	[A]	2,8	3	3,2	3,7	4,2		

## Model

Designation **CU GS26MFX MG\_Y 230/1/50 VAL**

Sales code: 314G7005

Engineering code: CUGS26MFX00VE

## Cooling performance - Conf. 2

Power supply	220-240V / 50Hz 1~	Voltage range	198 - 254V / 50Hz
Refr. charge - tech. limit	2000g / 70,5oz		
Starter	HST / capillary tube or expansion valve		
Motor configuration	CSCR		
Refrigerant	R513A		
Application	MBP		
Approvals	Eco design (EU) 2015/1095, CE, UK CA, VDE		

ambient temperature	[°C / °F]	25 / 77 (suction gas temperature [°C / °F]: 20 / 68, subcooling: 2K)						
evaporating temperature	[°C / °F]	-20 / -4	-17,8 / 0	-15 / 5	-10 / 14	-5 / 23	0 / 32	5 / 41
cooling capacity	[W]	939	1041	1177	1438	1718	2014	2321
COP	[W/W]	1,53	1,62	1,72	1,88	2,01	2,1	2,16
cooling capacity	[Btu/h]	3208	3555	4019	4910	5868	6880	7926
power consumption	[W]	612	644	686	765	854	957	1077
current consumption	[A]	2,9	3	3,2	3,6	4	4,5	5

ambient temperature	[°C / °F]	32 / 90 (suction gas temperature [°C / °F]: 20 / 68, subcooling: 2K)						
evaporating temperature	[°C / °F]	-20 / -4	-17,8 / 0	-15 / 5	-10 / 14	-5 / 23	0 / 32	5 / 41
cooling capacity	[W]	850	943	1065	1300	1549	1812	2082
COP	[W/W]	1,36	1,43	1,51	1,65	1,74	1,8	1,83
cooling capacity	[Btu/h]	2905	3219	3638	4438	5292	6188	7109
power consumption	[W]	624	658	703	790	889	1004	1138
current consumption	[A]	3	3,1	3,3	3,7	4,2	4,7	5,3

ambient temperature	[°C / °F]	38 / 100 (suction gas temperature [°C / °F]: 20 / 68, subcooling: 2K)						
evaporating temperature	[°C / °F]	-20 / -4	-17,8 / 0	-15 / 5	-10 / 14	-5 / 23	0 / 32	
cooling capacity	[W]	774	858	970	1180	1404	1637	
COP	[W/W]	1,22	1,28	1,35	1,45	1,52	1,56	
cooling capacity	[Btu/h]	2643	2931	3311	4031	4796	5591	
power consumption	[W]	635	672	720	815	923	1049	
current consumption	[A]	3	3,2	3,4	3,8	4,3	4,9	

ambient temperature	[°C / °F]	43 / 109 (suction gas temperature [°C / °F]: 20 / 68, subcooling: 2K)						
evaporating temperature	[°C / °F]	-20 / -4	-17,8 / 0	-15 / 5	-10 / 14	-5 / 23		
cooling capacity	[W]	708	785	887	1079	1280		
COP	[W/W]	1,1	1,15	1,21	1,29	1,34		
cooling capacity	[Btu/h]	2417	2681	3031	3685	4373		
power consumption	[W]	646	685	736	838	955		
current consumption	[A]	3,1	3,2	3,5	3,9	4,5		