

## Model

Designation

**CU NLE10MF.2 MG\_Y 230/1/50 CAP**



Sales code:

314G5006

Engineering code:

CUNLE10MF20CE

## Application Data

Power supply	220-240V / 50Hz 1~
Refrigerants	R134a-R513A
Refr. charge - tech. limit	600g / 21,2oz
Starter	HST / capillary tube or expansion valve
Sound pressure (10m)	28,5dB(A)

## Configuration data

	Conf. 1	Conf. 2
Voltage range	198 - 254V / 50Hz	198 - 254V / 50Hz
Refrigerant	R134a	R513A
Application	LBP+MBP	LBP+MBP
Rated performance	<u>pe=-10°C, Tsuc=20°C, Tamb=25°C, subcooling: 2K</u>	
Cooling capacity	581W / 1985Btu/h	608W / 2078Btu/h
Power consumption	272,3W	289,4W
Current consumption	1,8A	1,9A
COP/EER	2,13 / 7,29Btu/Wh	2,1 / 7,18Btu/Wh
Approvals	Eco design (EU) 2015/1095, CE, UK CA, VDE	Eco design (EU) 2015/1095, CE, UK CA, VDE

## Compressor

Designation	<b>NLE10MF.2</b>
Motor configuration	CSIR
Locked rotor amperage	11,3A
Rated load amperage	2,15A
Winding resistance main	9,28Ω
Winding resistance aux	11,64Ω
Oil quantity	300cm <sup>3</sup> / 10,1fl.oz
Oil type	POE
Horsepower rating	1/4 HP

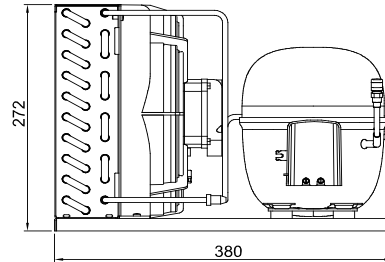

## Dimensions

### Condensing unit

Height x Width x Depth	272 x 300 x 380 [mm] / 10,7 x 11,8 x 15 [in]
Weight	16,3kg / 36lbs
Suction adapter	OD ø8mm / 1/3in
Discharge adapter	OD ø6mm / 1/4in
Process connector	ø6,2mm / 0,24in

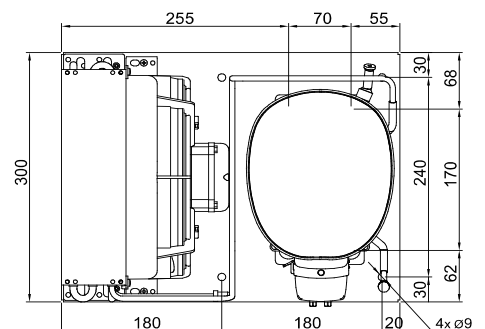

### Package data

Height x Width x Depth	350 x 400 x 500 [mm] / 13,8 x 15,7 x 19,7 [in]
Weight	19,3kg / 42,6lbs

### Model

Designation **CU NLE10MF.2 MG\_Y 230/1/50 CAP**

Sales code: 314G5006  
Engineering code: CUNLE10MF20CE

### Components Condensing-Unit / Spare Parts

Component	Type	Spare part code number
Compressor code	NLE10MF.2	105G7005
Condenser	Condenser (3 rows x 10 tubes)	SP 314S0002
Fan motor	10W	MP 314S0019
Blade code	ø230mm 28°	SP 314S0025
Air flow	462m³/h	
Receiver code	not installed	-/-
Suction valve code	OD ø8mm / 1/3in	-/-
Liquid valve code	OD ø6mm / 1/4in	-/-

Compressor starting equipment	Spare part code number
pos. a2 - assy. relay	117U6002
pos. c - start capacitor (80µF)	117U5015
pos. b - plastic cover	103N2010
pos. d - cord relief	103N1010

### Wiring Sketch Compressor

### Wiring Sketch Condensing Unit

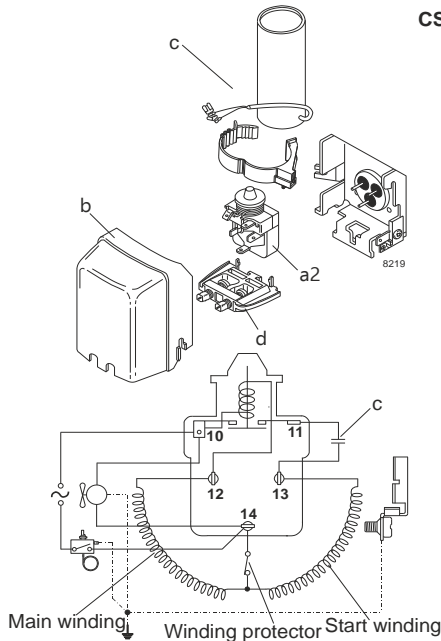

## Model

Designation **CU NLE10MF.2 MG\_Y 230/1/50 CAP**

Sales code: 314G5006

Engineering code: CUNLE10MF20CE

## Cooling performance - Conf. 1

Power supply	220-240V / 50Hz 1~	Voltage range	198 - 254V / 50Hz
Refr. charge - tech. limit	600g / 21,2oz		
Starter	HST / capillary tube or expansion valve		
Motor configuration	CSIR		
Refrigerant	R134a		
Application	LBP+MBP		
Approvals	Eco design (EU) 2015/1095, CE, UK CA, VDE		

ambient temperature	[°C / °F]	25 / 77 (suction gas temperature [°C / °F]: 20 / 68, subcooling: 2K)						
evaporating temperature	[°C / °F]	-35 / -31	-30 / -22	-25 / -13	-20 / -4	-10 / 14	0 / 32	10 / 50
cooling capacity	[W]	172	230	299	380	581	833	1127
COP	[W/W]	1,13	1,33	1,53	1,74	2,14	2,44	2,57
cooling capacity	[Btu/h]	588	786	1021	1299	1985	2844	3848
power consumption	[W]	152	173	196	219	272	341	438
current consumption	[A]	1,5	1,5	1,6	1,6	1,8	2	2,4

ambient temperature	[°C / °F]	32 / 90 (suction gas temperature [°C / °F]: 20 / 68, subcooling: 2K)						
evaporating temperature	[°C / °F]	-35 / -31	-30 / -22	-25 / -13	-20 / -4	-10 / 14	0 / 32	10 / 50
cooling capacity	[W]	160	215	278	352	533	760	1028
COP	[W/W]	1,05	1,24	1,41	1,58	1,88	2,1	2,17
cooling capacity	[Btu/h]	546	733	950	1202	1821	2597	3511
power consumption	[W]	152	174	197	223	283	362	473
current consumption	[A]	1,5	1,5	1,6	1,6	1,8	2,1	2,5

ambient temperature	[°C / °F]	38 / 100 (suction gas temperature [°C / °F]: 20 / 68, subcooling: 2K)						
evaporating temperature	[°C / °F]	-35 / -31	-30 / -22	-25 / -13	-20 / -4	-10 / 14	0 / 32	10 / 50
cooling capacity	[W]	137	189	249	318	486	697	948
COP	[W/W]	0,9	1,07	1,24	1,39	1,65	1,82	1,89
cooling capacity	[Btu/h]	467	647	852	1087	1661	2381	3237
power consumption	[W]	153	176	201	229	295	382	502
current consumption	[A]	1,5	1,5	1,6	1,6	1,8	2,2	2,6

ambient temperature	[°C / °F]	43 / 109 (suction gas temperature [°C / °F]: 20 / 68, subcooling: 2K)						
evaporating temperature	[°C / °F]	-35 / -31	-30 / -22	-25 / -13	-20 / -4	-10 / 14	0 / 32	
cooling capacity	[W]	115	167	224	290	448	649	
COP	[W/W]	0,77	0,95	1,11	1,26	1,48	1,64	
cooling capacity	[Btu/h]	394	569	766	990	1532	2215	
power consumption	[W]	150	175	202	231	303	396	
current consumption	[A]	1,5	1,5	1,6	1,6	1,9	2,2	

## Model

Designation **CU NLE10MF.2 MG\_Y 230/1/50 CAP**

Sales code: 314G5006

Engineering code: CUNLE10MF20CE

## Cooling performance - Conf. 2

Power supply	220-240V / 50Hz 1~	Voltage range	198 - 254V / 50Hz
Refr. charge - tech. limit	600g / 21,2oz		
Starter	HST / capillary tube or expansion valve		
Motor configuration	CSIR		
Refrigerant	R513A		
Application	LBP+MBP		
Approvals	Eco design (EU) 2015/1095, CE, UK CA, VDE		

ambient temperature	[°C / °F]	25 / 77 (suction gas temperature [°C / °F]: 20 / 68, subcooling: 2K)						
evaporating temperature	[°C / °F]	-35 / -31	-30 / -22	-25 / -13	-20 / -4	-10 / 14	0 / 32	10 / 50
cooling capacity	[W]	195	255	326	409	608	852	1130
COP	[W/W]	1,2	1,37	1,55	1,75	2,1	2,36	2,46
cooling capacity	[Btu/h]	666	872	1114	1395	2077	2910	3858
power consumption	[W]	163	186	210	234	289	361	460
current consumption	[A]	1,5	1,6	1,6	1,7	1,9	2,1	2,4

ambient temperature	[°C / °F]	32 / 90 (suction gas temperature [°C / °F]: 20 / 68, subcooling: 2K)						
evaporating temperature	[°C / °F]	-35 / -31	-30 / -22	-25 / -13	-20 / -4	-10 / 14	0 / 32	10 / 50
cooling capacity	[W]	179	235	300	375	553	770	1020
COP	[W/W]	1,08	1,24	1,41	1,57	1,83	2,01	2,06
cooling capacity	[Btu/h]	611	804	1026	1279	1888	2631	3484
power consumption	[W]	166	189	213	239	302	383	496
current consumption	[A]	1,5	1,6	1,6	1,7	1,9	2,1	2,5

ambient temperature	[°C / °F]	38 / 100 (suction gas temperature [°C / °F]: 20 / 68, subcooling: 2K)						
evaporating temperature	[°C / °F]	-35 / -31	-30 / -22	-25 / -13	-20 / -4	-10 / 14	0 / 32	10 / 50
cooling capacity	[W]	152	207	268	336	500	700	931
COP	[W/W]	0,9	1,08	1,23	1,37	1,59	1,73	1,77
cooling capacity	[Btu/h]	520	706	914	1148	1708	2389	3178
power consumption	[W]	168	192	218	246	315	405	527
current consumption	[A]	1,5	1,6	1,7	1,7	1,9	2,2	2,6

ambient temperature	[°C / °F]	43 / 109 (suction gas temperature [°C / °F]: 20 / 68, subcooling: 2K)						
evaporating temperature	[°C / °F]	-35 / -31	-30 / -22	-25 / -13	-20 / -4	-10 / 14	0 / 32	
cooling capacity	[W]	129	182	240	305	458	645	
COP	[W/W]	0,78	0,96	1,1	1,22	1,42	1,54	
cooling capacity	[Btu/h]	440	621	819	1041	1565	2203	
power consumption	[W]	165	190	218	249	323	420	
current consumption	[A]	1,5	1,6	1,7	1,7	2	2,2	