

Model

Designation **CU SC18MFX MG_Y 230/1/50 VAL**



Sales code: 314G4003
Engineering code: CUSC18MFX00VE

Application Data

Power supply	220-240V / 50Hz 1~
Refrigerants	R134a-R513A
Refr. charge - tech. limit	1300g / 45,9oz
Starter	HST / capillary tube or expansion valve
Sound pressure (10m)	37dB(A)

Configuration data

	Conf. 1	Conf. 2
Voltage range	187 - 254V / 50Hz	187 - 254V / 50Hz
Refrigerant	R134a	R513A
Application	MBP	MBP

Rated performance	<u>pe=-10°C, Tsuc=20°C, Tamb=25°C, subcooling: 2K</u>	
Cooling capacity	886W / 3028Btu/h	927W / 3166Btu/h
Power consumption	497,6W	533,1W
Current consumption	3,3A	3,5A
COP/EER	1,78 / 6,08Btu/Wh	1,74 / 5,94Btu/Wh

Approvals	Eco design (EU) 2015/1095, CE, UK CA, VDE	Eco design (EU) 2015/1095, CE, UK CA, VDE
-----------	--	--

Compressor

Designation	SC18MFX
Motor configuration	CSIR
Locked rotor amperage	20,43A
Rated load amperage	3,9A
Winding resistance main	3,7Ω
Winding resistance aux	14Ω
Oil quantity	550cm ³ / 18,6fl.oz
Oil type	POE
Horsepower rating	3/8 HP

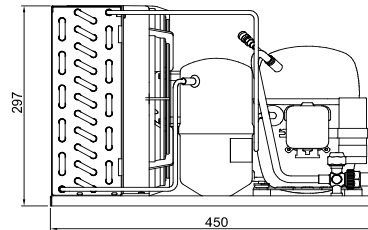

Dimensions

Condensing unit

Height x Width x Depth	297 x 350 x 450 [mm] / 11,7 x 13,8 x 17,7 [in]
Weight	27,9kg / 61,6lbs
Suction adapter	FLARE 3/8"
Discharge adapter	FLARE 1/4"
Process connector	ø6,2mm / 0,24in

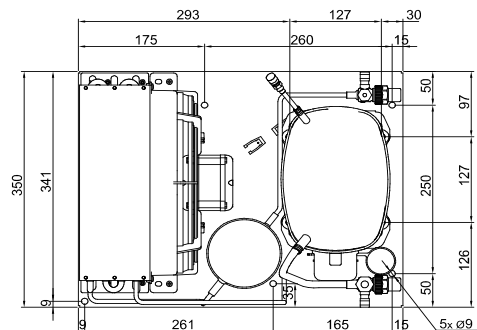

Package data

Height x Width x Depth	350 x 450 x 550 [mm] / 13,8 x 17,7 x 21,7 [in]
Weight	30,9kg / 68,2lbs

Model

Designation **CU SC18MFX MG_Y 230/1/50 VAL**

Sales code: 314G4003
Engineering code: CUSC18MFX00VE

Components Condensing-Unit / Spare Parts

Component	Type	Spare part code number
Compressor code	SC18MFX	104G8804
Condenser	Condenser (4 rows x 11 tubes)	SP 314S0004
Fan motor	16W	MP 314S0021
Blade code	ø254mm 22°	SP 314S0026
Air flow	519,9m³/h	
Receiver code	Receiver 1,3 liter	MP 314S0036
Suction valve code	FLARE 3/8"	FLARE 3/8"
Liquid valve code	FLARE 1/4"	FLARE 1/4"

Compressor starting equipment	Spare part code number
pos. a2 - relay	117U6019
pos. c - start capacitor (80µF)	117U5017
pos. d - cord relief	103N1004
pos. b - plastic cover	103N2009

Wiring Sketch Compressor

Wiring Sketch Condensing Unit

CSIR

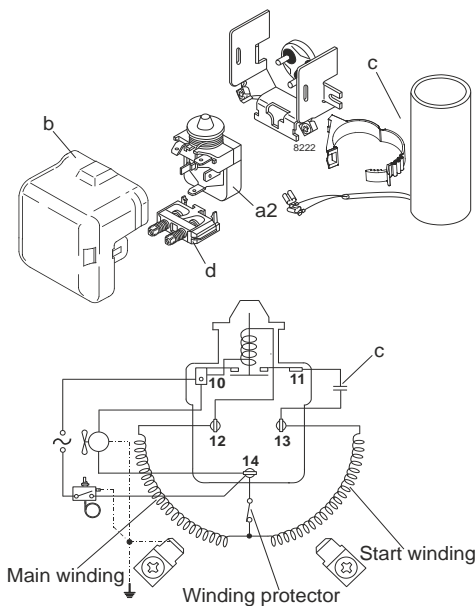

Model

Designation **CU SC18MFX MG_Y 230/1/50 VAL**

Sales code: 314G4003

Engineering code: CUSC18MFX00VE

Cooling performance - Conf. 1

Power supply	220-240V / 50Hz 1~	Voltage range	187 - 254V / 50Hz
Refr. charge - tech. limit	1300g / 45,9oz		
Starter	HST / capillary tube or expansion valve		
Motor configuration	CSIR		
Refrigerant	R134a		
Application	MBP		
Approvals	Eco design (EU) 2015/1095, CE, UK CA, VDE		

ambient temperature	[°C / °F]	25 / 77 (suction gas temperature [°C / °F]: 20 / 68, subcooling: 2K)						
evaporating temperature	[°C / °F]	-25 / -13	-20 / -4	-15 / 5	-10 / 14	0 / 32	5 / 41	10 / 50
cooling capacity	[W]	448	572	718	886	1289	1520	1769
COP	[W/W]	1,19	1,38	1,58	1,78	2,14	2,29	2,4
cooling capacity	[Btu/h]	1531	1955	2453	3027	4402	5192	6041
power consumption	[W]	378	415	455	498	601	664	738
current consumption	[A]	2,9	3	3,2	3,3	3,7	4	4,2

ambient temperature	[°C / °F]	32 / 90 (suction gas temperature [°C / °F]: 20 / 68, subcooling: 2K)						
evaporating temperature	[°C / °F]	-25 / -13	-20 / -4	-15 / 5	-10 / 14	0 / 32	5 / 41	10 / 50
cooling capacity	[W]	404	520	655	810	1181	1394	1622
COP	[W/W]	1,07	1,24	1,41	1,58	1,87	1,99	2,07
cooling capacity	[Btu/h]	1380	1774	2235	2766	4033	4759	5540
power consumption	[W]	379	421	466	514	631	702	785
current consumption	[A]	2,9	3,1	3,2	3,4	3,8	4,1	4,4

ambient temperature	[°C / °F]	38 / 100 (suction gas temperature [°C / °F]: 20 / 68, subcooling: 2K)						
evaporating temperature	[°C / °F]	-25 / -13	-20 / -4	-15 / 5	-10 / 14	0 / 32	5 / 41	
cooling capacity	[W]	368	476	601	746	1088	1285	
COP	[W/W]	0,97	1,12	1,27	1,41	1,65	1,74	
cooling capacity	[Btu/h]	1256	1625	2054	2546	3717	4390	
power consumption	[W]	378	425	475	529	659	739	
current consumption	[A]	2,9	3,1	3,3	3,5	3,9	4,2	

ambient temperature	[°C / °F]	43 / 109 (suction gas temperature [°C / °F]: 20 / 68, subcooling: 2K)						
evaporating temperature	[°C / °F]	-25 / -13	-20 / -4	-15 / 5	-10 / 14	0 / 32		
cooling capacity	[W]	339	440	558	693	1012		
COP	[W/W]	0,9	1,03	1,16	1,28	1,47		
cooling capacity	[Btu/h]	1157	1504	1906	2366	3456		
power consumption	[W]	376	428	483	543	687		
current consumption	[A]	2,9	3,1	3,3	3,5	4		

Model

Designation **CU SC18MFX MG_Y 230/1/50 VAL**

Sales code: 314G4003

Engineering code: CUSC18MFX00VE

Cooling performance - Conf. 2

Power supply	220-240V / 50Hz 1~	Voltage range	187 - 254V / 50Hz
Refr. charge - tech. limit	1300g / 45,9oz		
Starter	HST / capillary tube or expansion valve		
Motor configuration	CSIR		
Refrigerant	R513A		
Application	MBP		
Approvals	Eco design (EU) 2015/1095, CE, UK CA, VDE		

ambient temperature	[°C / °F]	25 / 77 (suction gas temperature [°C / °F]: 20 / 68, subcooling: 2K)						
evaporating temperature	[°C / °F]	-25 / -13	-20 / -4	-15 / 5	-10 / 14	0 / 32	5 / 41	10 / 50
cooling capacity	[W]	485	611	759	927	1322	1545	1782
COP	[W/W]	1,17	1,35	1,55	1,74	2,08	2,21	2,31
cooling capacity	[Btu/h]	1657	2088	2592	3166	4514	5277	6085
power consumption	[W]	413	451	491	533	635	698	773
current consumption	[A]	3,1	3,2	3,3	3,5	3,9	4,1	4,4

ambient temperature	[°C / °F]	32 / 90 (suction gas temperature [°C / °F]: 20 / 68, subcooling: 2K)						
evaporating temperature	[°C / °F]	-25 / -13	-20 / -4	-15 / 5	-10 / 14	0 / 32	5 / 41	10 / 50
cooling capacity	[W]	436	553	688	841	1201	1403	1617
COP	[W/W]	1,05	1,21	1,37	1,53	1,8	1,9	1,96
cooling capacity	[Btu/h]	1488	1887	2348	2873	4100	4792	5524
power consumption	[W]	415	458	502	551	667	738	823
current consumption	[A]	3,1	3,2	3,4	3,6	4	4,2	4,5

ambient temperature	[°C / °F]	38 / 100 (suction gas temperature [°C / °F]: 20 / 68, subcooling: 2K)						
evaporating temperature	[°C / °F]	-25 / -13	-20 / -4	-15 / 5	-10 / 14	0 / 32	5 / 41	
cooling capacity	[W]	395	503	628	769	1097	1281	
COP	[W/W]	0,95	1,09	1,22	1,36	1,57	1,65	
cooling capacity	[Btu/h]	1349	1719	2144	2625	3746	4374	
power consumption	[W]	415	462	513	567	697	778	
current consumption	[A]	3,1	3,2	3,4	3,6	4,1	4,4	

ambient temperature	[°C / °F]	43 / 109 (suction gas temperature [°C / °F]: 20 / 68, subcooling: 2K)						
evaporating temperature	[°C / °F]	-25 / -13	-20 / -4	-15 / 5	-10 / 14	0 / 32		
cooling capacity	[W]	363	463	579	709	1010		
COP	[W/W]	0,88	0,99	1,11	1,22	1,39		
cooling capacity	[Btu/h]	1238	1583	1976	2420	3450		
power consumption	[W]	413	466	522	583	726		
current consumption	[A]	3,1	3,3	3,5	3,7	4,2		